

' TRUFLO '

SINGLE ANVIL PINCH VALVE

ATVAL'S Hi-Tech Alternative to the Matronly Diaphragm Valve!



- STRAIGHT LINE FLOW, NO CAVITIES.
- DROP TIGHT BI-DIRECTIONAL SHUT OFF.
- EASY TO USE, EASY TO MAINTAIN, FITTER FRIENDLY
- ALL TYPES OF ACTUATORS CAN BE FITTED.
- SELF CLEANING FLEXING ACTION OF SLEEVE ELIMINATES IN LINE SCALING AND LINE BLOCKAGE.
- FIELD REPLACEABLE SLEEVE EXTENDS IN LINE SERVICE AND LOWERS MAINTENANCE COSTS.
- SLEEVES AVAILABLE IN A WIDE RANGE OF POLYMERS AND TRIMS TO MEET EXACT SERVICE AND FLOW SPECIFICATIONS.
- ALL MECHANICAL PARTS COMPLETELY ISOLATED FROM PIPE LINE MEDIUM.
- SIZES 25mm TO 300mm. NORMAL CWP 1000kPa. FOR HIGHER PRESSURES CONSULT OUR FACTORY.

'TRUFLO'

SINGLE ANVIL PINCH VALVE

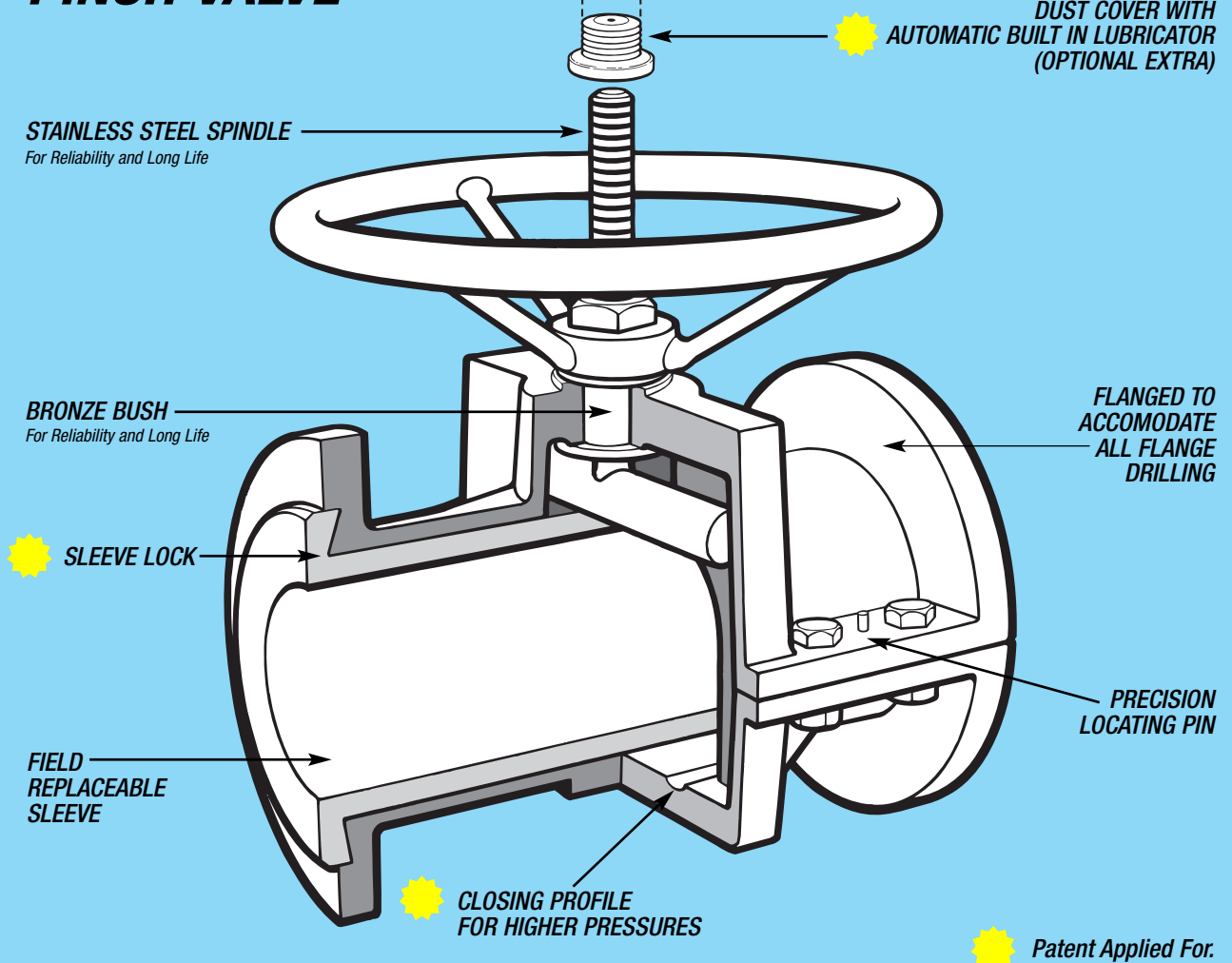

Designed and Produced by Ancher Martin Graphics (011) 435-5495 072 606 4140

Valve Size	25	40	50	65	80	100	125	150	200	250	300
Face to Face	134	166	198	225	263	312	365	415	535	644	760
Centre to Top (open)	100	140	150	180	215	265	300	350	400	550	630
Handwheel	110	110	150	150	200	250	250	300	350	500	600
Weight	5	7	10	13	18	26	40	55	100	170	220

Body	Sleeve Rubbers	Spindle
Cast Iron	Gum	Stainless 304
Aluminium	Natural	Stainless 316
Coated (Specify)	Synthetic	To Customer Specification

Other valve sizes available - Please consult our factory.



Australian Operations
Ventomat Australia Pty Ltd
 5 Vangeli St, Arndell Park
 NSW, 2148, P.O. Box 156
 Seven Hills, NSW, 1730
 Tel: +61-2-8814-9699
 Fax: +61-2-8814-9666
 email:sales@ventomat.com.au
 www.ventomat.com.au

MANUFACTURERS OF :

- PINCH VALVES
- KNIFE GATE VALVES
- NON RETURN VALVES
- EXPANSION JOINTS
- RUBBER LINING
- PINCH VALVE SLEEVES
- SHORT HOSE
- HOSE BENDS
- GENERAL RUBBER PRODUCTS
- VALVE REPAIR SERVICES

Distributors of : All types of Industrial Valves - Valve Actuators - High Pressure Hose - Rubber Sheet.